

Narco Avionics

AT165 TSO (KT76/78 replacement) Transponder VALUE SERIES



Installation Manual
03609-0620K1VS

APPROVED FOR OPERATION UP TO 30,700 FT

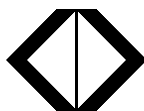

Narco Avionics Inc.
270 Commerce Drive, Suite 200
Ft. Washington, Pa. 19034
U.S.A.

NOTICE

While every effort has been made by Narco Avionics Inc. to ensure accuracy in the preparation of this Installation Manual, Narco assumes no responsibility for errors or omissions

Narco Avionics can be reached by calling :

Phone : 215-643-2900

FAX : 215-643-0197

Or on the Internet at www.narcoavionics.com

The AT165 is dedicated to John Bail (1929-2003). John , as Vice President of Engineering and later as a consultant, was instrumental in the development of many of Narco's best selling products including the AT165.

Narco Avionics AT165 TSO
TABLE OF CONTENTS

SECTION NUMBER	TITLE	PAGE NUMBER
1.1	GENERAL	1-1
1.1.1	Manual Organization	1-1
1.2	PRODUCT DESCRIPTION	1-1
1.3	PRODUCT SPECIFICATIONS	1-2
1.4	TSO EXPLANATION	1-3
1.4.1	Antenna requirements	1-3
1.5	UNITS AND ACCESSORIES SUPPLIED	1-3
1.6	OPERATOR LICENSE REQUIREMENTS	1-3
1.7	OPERATION	1-4
1.7.1	Function Selector Switch	1-4
1.7.2	Code Select/Data Entry	1-5
1.7.3	Ident	1-5
1.7.4	Vfr	1-5
2.1	INTRODUCTION	2-1
2.2	PRELIMINARY INSPECTION	2-1
2.2.1	Unpacking	2-1
2.2.2	Electrical Test.	2-2
2.2.2.1	Test Equipment Required.	2-2
2.2.2.2	Test Procedure	2-2
2.3	MECHANICAL INSTALLATION.	2-5
2.3.1	Removal of the KT76	2-5
2.3.2	Installation Of The AT165	2-5
2.4	ELECTRICAL INSTALLATION	2-5
2.4.1	Power And Interconnect	2-5
2.4.2	Back Lighting	2-6
2.4.3	External Suppression	2-6
2.4.4	Remote IDENT	2-6
2.4.5	Altitude Digitizer	2-6
2.5	POST INSTALLATION TESTS	2-6
2.5.1	Preflight Tests	2-7
2.5.2	Setup	2-8
2.5.3	Flight Test	2-8
2.6	AIRCRAFT LICENSE REQUIREMENTS.	2-9
	APPENDIX A – CERTIFICATION DOCUMENTS	
A.1	ENVIRONMENTAL QUALIFICATION FORM	A-1
A.2	CONTINUED AIRWORTHINESS	A-2
R.1	MANUAL REVISION HISTORY	R-1

LIST OF ILLUSTRATIONS

FIGURE NUMBER	TITLE	PAGE NUMBER
1-1	AT165 TSO FRONT PANEL	1-4
2-1	BENCH TEST SET-UP	2-2

LIST OF TABLES

TABLE NUMBER	TITLE	PAGE NUMBER
1.1	UNITS AVAILABLE	1-3
2.1	ALTITUDE DIGITIZER INPUTS	2-4

1.1 GENERAL

In support of the Narco Avionics AT165 TSO (KT76 Replacement) Transponder, this manual provides detailed installation and operation procedures.

"This manual is intended for use only by persons qualified to install equipment in this manual pursuant to current regulatory requirements."

1.1.1 Manual Organization

Organized into two major sections the manual includes the following:

Section 1, Introduction - general information required in planning the installation

Section 2, Installation - detailed procedures for performing the mechanical and electrical installation

1.2 PRODUCT DESCRIPTION

The AT165 TSO (KT76 Replacement herein referred to as the AT165) is a panel mounted unit designed to be a slide in replacement for existing KT76 installations. The AT165 provides all the features of KT76 with additional enhancements.

The AT165 TSO is a panel-mounted transponder with easy push button VFR recall. The AT165 consists of a receiver tuned to the frequency of a ground interrogation station (1030 MHz), logic circuitry to check the validity of the received interrogation and encode a reply containing pertinent identification information, and a transmitter which sends the coded reply to the ground station. When connected to an optional Altitude Digitizer (AR850) coded altitude information will be transmitted to the ground station.

The AT165 utilizes a single knob for error free code entry even in turbulence. Push button controls are used to access and manipulate the added feature. The front panel display has a single LCD display of primary transponder functions.

The AT165 has been designed for 14V or 28V operation. If the AT165 is replacing a KT76 that uses a passive voltage converter this does not have to be removed.

1.3 PRODUCT SPECIFICATIONS

Mechanical

Installation Space 6.25 in. (15.87 cm) x 1.63 in. (4.14 cm) x 10.0 in. (25.4 cm)
 Weight 1.8lbs. (.82kg)

Electrical

Power Requirements	13.75 VDC	27.5VDC
Standby	575mA	460mA
Transmit	1.75 A	880mA
OFF (Pilot Lamps)	260mA	260mA
Dimmer Buss	14 μ A	28 μ A

Receiver

Frequency 1030 MHz
 Sensitivity Minimum trigger level (MTL) -69 to -74 dBm
 Side-Lobe Suppression (SLS) 99% or greater for signals from 3 dB to 50 dB above MTL
 Dynamic Range Logarithmic pulse response 50 dB or greater above MTL
 Bandwidth -60dB at \pm 25 MHz

Decoding Capability

Mode A Pulse pair spaced at $8 \pm 0.5\mu$ s
 Mode C Pulse pair spaced at $21 \pm 0.5\mu$ s

Side-Lobe Suppression

35 μ s suppression upon receipt of two pulses spaced $2 \pm 0.5\mu$ s apart.

Encoding Capability

Mode A 4096 reply codes selectable by front panel switches.
 Mode C Altitude reporting to 30,700 feet
 SPIP (Special Position Identification Pulse) An SPIP may be added to mode A for 20 ± 5 seconds

Transmitter

Frequency 1090 MHz
 Pulse Power 250 watts nominal, 190 watts minimum

External Interference Suppression (positive)

Pulse Amplitude 5 to 50 volts
 Load on Suppressor 3300 ohms

External Interference Suppression (negative)

Voltage 0.8V (maximum)
 Current 5 mA

1.4 TSO EXPLANATION

The TSO'd AT165 is designed to be instrument panel mounted within the cabin environment of fixed and rotary wing aircraft using piston or turbine single or multi-engines. It will operate and has been tested up to 30,000 feet for installations in non-pressurized as well as pressurized aircraft. This equipment requires direct current power but is designed to be installed in aircraft that have additional on board alternating current sources. Environmental testing was done to RTCA Document DO-160C. The Environmental categories are listed in Appendix A of this document.

1.4.1 Antenna

The Antenna should meet the requirements of TSO-C74b Class 1.

1.5 UNITS AND ACCESSORIES SUPPLIED

The following two tables may be used to: 1) check the contents of your order and, 2) to order additional Units or components.

TABLE 1.1 UNITS AVAILABLE

Unit Part Number	Unit and Description	Subassembly Part Number
03609-0308	AT165 TRANSPONDER ASSY, (KT76 REPLACEMENT)	01550-0107
	7/64 Allen Wrench	84195-0001

1.6 OPERATOR LICENSE REQUIREMENTS

The Telecommunications Act of 1996, effective February 8, 1996 allowed the FCC the ability to eliminate the need for Aircraft Radio Station Licenses for domestic operation. The AT165 installation must comply with current FCC transmitter licensing requirements. To find out current details contact the FCC at 800-322-1117 or check the web at www.fcc.gov. The AT165 owner is responsible for obtaining proper licensing (if needed) before using the transponder.

1.7 OPERATION



FIGURE 1-1 AT 165 FRONT PANEL

1.7.1 FUNCTION SELECTOR SWITCH

The function selector is a four position rotary switch. The four positions are:

- OFF-** Turns off all power to the transponder.
- SBY-** Turns the transponder power supply on. When in **SBY**, the transponder will not reply to any interrogation. **SBY** is used at the request of the air traffic controller to selectivity clear his scope of traffic. When in this mode SBY will be shown on the Code display window.
- ON-** Places the transponder in Mode A, the aircraft identification mode. In addition to the aircraft's identification code, the transponder will also reply to altitude interrogations (Mode C) with discrete signals that do not contain altitude information. When in this mode ON will be shown on the Code display window.
- ALT-** The **ALT** position activates all the necessary circuitry (transponder to optional altitude digitizer and return) to respond to ATC (Air Traffic Control) altitude interrogations and aircraft identification interrogations with standard pressure altitude (29.92 inches Hg). The **ALT** position may be used in aircraft that are not equipped with the optional altitude digitizer, however, the only response will be discrete signals that do not contain altitude information. When in this mode ALT will be shown on the Code display window.

1.7.2 CODE SELECTOR/DATA ENTRY SWITCH

Pressing the Code Selector/Data Entry Switch once enables Transponder Code entry. The left most code digit will begin flashing. Turning the switch selects the code and pushing the switch again moves to the next digit from left to right. Once code selection has started, all four digits must be set before the code entry is completed. A total of 5 pushes completes the code entry process. If the switch is inadvertently pressed, it will stop the code entry process automatically in 10 seconds. The VFR code can subsequently be recalled automatically by pressing the VFR button. Code entry can not be started if the AT165 is in setup, Count Down Timer set, or Altitude Buffer set modes.

1.7.3 IDENT

Pressing the **IDENT** button will activate the SPIP (Special Position Identification Pulse) signal for approximately 20 seconds. This signal will "paint" an instantly identifiable image on the controller's scope. This signal must only be used upon request of a "Squawk IDENT" from the controller. Use at any other time could interfere with another aircraft sending a SPIP. The IDENT legend will appear in the Code window while the Ident signal is being sent.

1.7.4 VFR

Pressing the **VFR** button will cause the squawk code to either change from the user entered code to a VFR code or change back to the user entered code from the currently displayed VFR code. The last used squawk code is automatically recalled when the unit is cycled off and on.

THIS PAGE INTENTIONALLY LEFT BLANK

2.1 INTRODUCTION

This section provides the necessary information for the installation of the AT165 TSO and, where required, optional accessories.

2.2 PRELIMINARY INSPECTION

2.2.1 Unpacking

Carefully unpack the Unit and inspect it for any damage that may have occurred during shipment. Refer to Section 1.5, Units and Accessories Supplied, and inventory the contents.

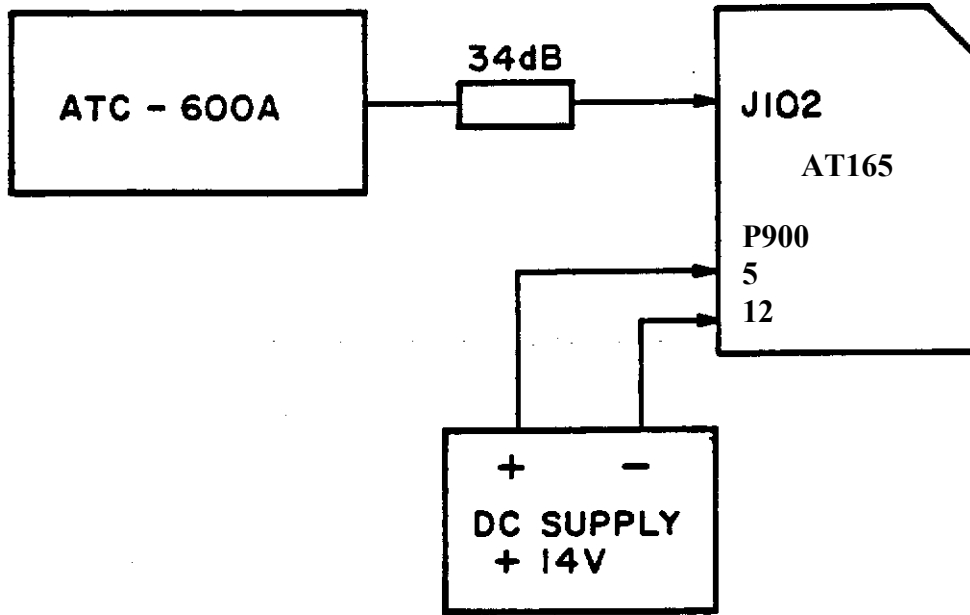

FIGURE 2-1. BENCH TEST SET-UP

2.2.2 Electrical Test

2.2.2.1 Test Equipment Required

- A. Transponder and DME Test Set: IFR Model ATC-600A or equivalent.
- B. 34 dB attenuation pad.

2.2.2.2 Test Procedure

A. Set-Up

- 1. The AT165 should be tested while contained in the mounting tray with the RF cable installed.
- 2. When the AT165 is being interrogated by the ATC-600A, the RCV legend will be ON.

B. Receiver Sensitivity

- 1. Place the AT165 in the ON mode. Place the ATC-600A in the A/C CODE mode.
- 2. Rotate the ATC-600A XPDR SIG. level control full counterclockwise. The % scale of the XPDRRPLY meter should read 100%.
- 3. Rotate the XPDR SIG level control clockwise until the XPDR RPLY meter reads 90%.
- 4. The XPDR SIG level control indicator should be between -69 and -74 dBm. This is the MTL of the transponder.

2.2.2.2 Continued

5. Repeat steps 2, 3, and 4 with the AT165 in the ALT mode and the ATC-600A in the A/C ALT mode. The difference between the MTL readings should not be greater than 1 dBm.

C. SLS Side-Lobe Suppression

1. Place the AT165 in the ON mode. Place the ATC-600A in the A/C CODE mode.
2. Rotate the XPDR SIG. level control full counterclockwise. The XPDR RPLY meter should read 100%.
3. Set the XPDR SIG. level control to 3 dB above MTL level established in step B-4.
4. Set the SLS switch to 0 dB. The XPDR RPLY meter should read zero.
5. Set the SLS switch to 9 dB. The XPDR RPLY meter should read 90% minimum.

D. Code Selection

1. Place the AT165 in the ON mode. Place the ATC-600A to the A/C CODE mode.
2. The ATC-600A numerical display should display the code selected by the AT165. Several different codes should be selected.
3. Consider the AT165 Code Display Digits to be labeled A, B, C, and D (left to right). Digit A should light the ATC-600A Binary Readout lamp A_1 when it is in the 1 position, the A_2 lamp in the 2 position, and the A_1 and A_2 lamps in the 3 position. In each digit position, the sum of the subscripts of the Binary Readout lamps that light should equal the number selected.
4. Repeat the above procedure for digits B, C, and D.

E. Transmitter Frequency

1. Place the AT165 in the ON mode and set the Code to 0000.
2. Place the ATC-600A in the A/C CODE mode and set the POWER/FREQ switch to FREQ.
3. Adjust the GAIN control for a mid-scale reading on the POWER meter.
4. Rotate the XMTR FREQ control for a peak Indication on the POWER meter.
5. At peak, read the deviation from 1090 MHz directly from the XMTR FREQ control dial. The deviation should be no greater than ± 3 MHz.

F. Transmitter Power

1. Place the AT165 in the ON mode and set the Code to 6050.
2. Place the ATC-600A in the A/C CODE mode and set the POWER/FREQ switch to POWER.
3. Read 190 watts (minimum) on the POWER meter.

G. Ident

1. Place the AT165 in the ON mode. Place the ATC-600A in the A/C CODE mode.
2. Momentarily depress the IDENT button on the AT165.
3. The AT165 IDENT legend and the ATC-600A IDENT lamp should be active for approximately 20 ± 5 seconds.

2.2.2.2 Continued

H. Altitude Digitizer Inputs

The following procedure is a functional check of the Altitude Digitizer Inputs P101-6 through P101-14 only. Therefore, the numerical readout and INVALID ALT lamp on the ATC-600A should be ignored.

1. Place the AT165 in the ALT mode. Place the ATC-600A in the A/C ALT mode.
2. Placing an Altitude Digitizer Input at ground potential will activate a corresponding Binary Readout lamp on the ATC-600A. Table 2.1 lists the P900 pin numbers and their corresponding ATC-600A Binary Readout lamps.

TABLE 2.1 ALTITUDE DIGITIZER INPUTS

GROUND P900	ACTIVATE ATC-600A BINARY READOUT LAMP
7	A ₂
6	A ₁
9	A ₄
2	B ₄
1	B ₂
8	C ₂
4	B ₁
10	C ₄
3	C ₁

I. Back Lighting

With voltage applied on the Avionics Buss, applying a voltage to the Dimmer Buss will cause the AT165 backlighting to illuminate. The intensity of the backlighting is controlled by the front panel photocell.

Disconnect the transponder from the Test Set-Up.

2.3 MECHANICAL INSTALLATION

2.3.1 Removal Of The KT76

Using a 3/32" Allen wrench through the face plate, turn the wrench counter clockwise until the KT76 disengages from the tray slot. The KT76 can now be removed from the tray.

2.3.2 Installation Of the AT165

Carefully inspect the card edge connector pins and the RF connector for damage before installing the AT165. Any damage should be repaired before installing and using the AT165.

Looking at the bottom of the AT165, make sure that the front lobe of the hold down device is in the vertical position (this can be accomplished by using the supplied 7/64" Allen wrench through the front panel).

Slide the AT165 into the tray until the front lobe touches the tray. Turn the Allen wrench clockwise until the rear lobe engages with the tray slot. Continue turning the wrench clockwise until tight (caution do not over tighten).

2.4 ELECTRICAL INSTALLATION

2.4.1 Power And Interconnect

TRAY CONNECTIONS

P900	CIRCUIT DESCRIPTION
5	13.75 VOLT INPUT
6	A1
7	A2
9	A4
4	B1
1	B2
2	B4
3	C1
8	C2
10	C4
11	14V DIMMER
12	GROUND

2.4.2 Backlighting

Pilot lamp 14/28V OPERATION

The AT165 backlighting is activated when a voltage is present on the Aircraft Dimmer Buss and the Avionics Buss is active (If there is no Dimmer Buss the dimmer pin can be connected to the Avionics Buss).

2.4.3 External Suppression

Not Available.

2.4.4 Remote IDENT

Not Available.

2.4.5 Altitude Digitizer

P900 pins 6, 7, 9, 4, 1, 2, 3, 8, AND 10 provide for the connection of an altitude digitizer. The altitude digitizer, sensing atmospheric pressure, converts pressure/altitude information into digitized altitude data. This data is then transmitted to the control center by the transponder. Narco recommends the Model AR 850 for this application.

2.5 POST INSTALLATION TESTS

To certify the installation, FAA Form 337 must be completed. In addition, weight and balance or any operating limitations must be entered into the aircraft logbook. Refer to the current Federal Aviation Regulations for any additional requirements.

Weight	1.8 lbs. (.82 kg)		
Power Requirements		13.75 VDC	27.5VDC
	Standby	575mA	460mA
	Transmit	1.75 A	880mA
	OFF (Pilot Lamps)	260mA	260mA
	Dimmer Buss	14 μ A	28 μ A

2.5.1 Preflight Tests

A. A preflight test should be performed using an ATC-600A Transponder and DME test set or equivalent. The test set should be set-up as described in the ATC-600A Operators Manual and following tests should be conducted:

1. Pilot Code
2. Peak Transmitter Power
3. Transmitter Frequency
4. SLS Operation
5. IDENT
6. Percent Reply

B. In the event that an altitude digitizer has been installed, the altitude digitizer manual should be consulted for proper procedures and the following tests should be conducted:

1. Altitude Code
2. Invalid Altitude Code Output

2.5.2 SETUP

Starting with the AT165 turned off, hold in the VFR button while turning the function switch to the SBY position. The AT165 will now be at the contrast adjust screen. Rotating the data entry switch CW or CCW will adjust the display's contrast. Once the desired contrast is achieved pressing the VFR button will save this setting and continue to the VFR set screen.

The VFR set screen allows the setting of the code displayed when the VFR button is pressed. Rotating the data entry switch will change the digit value and pressing the data entry switch will change the flashing cursor to the next digit. Pressing the VFR button will save the new VFR value and continue to the Display mode screen.

The Display mode screen allows three choices for the display: AUTO (A), POS (P), and NEG (N)

AUTO – Black letters on a light background switching to light letters on a black background as the ambient light is reduced.

POS- Black letters on a light background.

NEG – Light letters on a black background.

Pressing the VFR button will save the Display mode setting exit setup.

2.5.3 Flight Test

After installation, a flight test should be performed to check overall operation and system compatibility.

A. Range Test

1. The AT165 should furnish a strong and stable return signal to an interrogating radar facility that is 50 NM away when the aircraft is flying at 6000 feet. At this altitude and distance, fly a flat circle while having a FAA station monitor the transponder return signal. There should be no more than two sweeps of the interrogating radar without a return response.

B. Surveillance Approach

1. Perform an approach to a runway of an airport starting at least 10 NM from the airport served by Airport Surveillance Radar (ASR) having an Air Traffic Control Radar Beacon System (ATCRBS) facility. Alternately, a simulated approach and letdown may be made along a path parallel to, but separated, three to four miles from a vertical plane through the location of the ASR facility. The approach should be made at the normal rate of decent and normal approach and landing configuration for the aircraft and should continue down to an altitude of 200 feet. Not more than one "drop out" should occur for any 10 radar sweeps during final approach.

C. Electromagnetic Compatibility

1. The transponder should not cause the performance of other systems aboard the aircraft to be degraded below their normal capability and transponder operation should not be adversely affected by other equipment.

2.6 AIRCRAFT LICENSE REQUIREMENTS

The AT165 installation must comply with current FCC transmitter licensing requirements. To find out specific details on whether a particular installation requires licensing contact the FCC at 800-322-1117.

If an aircraft license is required, make application for a license on FCC form 404, Application for Aircraft Radio Station License.

The aircraft owner accepts all responsibility for obtaining the proper licensing before using the AT165

This equipment has been type accepted by the FCC and entered in their list of type accepted equipment under the FCC identifier "A9SAT165".

This page intentionally left blank.

APPENDIX A

A.1 ENVIRONMENTAL QUALIFICATION FORM

NOTE : A COPY OF THIS FORM IS TO BE FILED WITH THE OWNER'S AVIONICS RECORDS.

NOMENCLATURE : TRANSPONDER
MODEL : AT165
MANUFACTURER : Narco Avionics Inc.
ADDRESS : 270 Commerce Drive
Fort Washington, PA 19034
USA

CONDITIONS	DO-160C SECTION, PARAGRAPH#	DESCRIPTION OF CONDUCTED TESTS
Temperature and Altitude	4.0	Equipment tested to category "A1C1"
Ground Survival Low Temperature	4.5.1	-55°C
Operating Low Temperature	4.5.1	-20°C
Ground Survival High Temperature	4.5.2	+85°C
Short-Time High Operating Temperature	4.5.2	+75°C
Operating High Temperature	4.5.3	+55°C
In Flight Loss of Cooling	4.5.4	Equipment tested to category "V", Greater than 30 Minutes
Altitude	4.6.1	35,000 feet (10,668 meters)
Decompression	4.6.2	8,000 feet to 35,000 feet Δ within 15 seconds, then maintained for 10 minute minimum duration.
Overpressure	4.6.3	-15,000 feet for 10 minutes
Temperature Variation	5.0	Equipment tested to category "C".
Humidity	6.0	Equipment tested to category "A".
Operational Shocks and Crash Safety	7.0	Equipment tested to operational and crash safety tests.
Operational	7.2	
Crash Safety	7.3	
Vibration	8.0	Equipment tested without shock mounts to Categories M, N and B (DO-160C Table 8-1)
Explosion	9.0	Equipment identified as Category "X", no test required.
Waterproofness	10.0	Equipment identified as Category "X", no test required.
Fluids Susceptibility	11.0	Equipment identified as Category "X", no test required.
Sand and Dust	12.0	Equipment identified as Category "X", no test required.
Fungus	13.0	Equipment identified as Category "X", no test required.
Salt Spray	14.0	Equipment identified as Category "X", no test required.
Magnetic Effect	15.0	Equipment tested to Category "Z"
Power Input	16.0	Equipment tested to Category "B"
Voltage Spike	17.0	Equipment tested to Category "B"
Audio Frequency Susceptibility	18.0	Equipment tested to Category "B"
Induced Signal Susceptibility	19.0	Equipment tested to Category "A"
Radio Frequency Susceptibility	20.0	Equipment tested to Category "T"
Radio Frequency Emission	21.0	Equipment tested to Category "B"
Lightning Induced Transient Susceptibility	22.0	Equipment identified as Category "X", no test required.
Lightning Direct Effects Test	23.0	Equipment identified as Category "X", no test required.
Icing	24.0	Equipment identified as Category "X", no test required.
Other Test		Fire resistance tests were conducted in accordance with Federal Aviation Regulations Part 15, Appendix F.

A.2 CONTINUED AIRWORTHINESS

Other than for regulatory periodic functional checks, the AT165 does not require periodic maintenance. If the AT165 exhibits non-conformal operation, the AT165 should be checked at a qualified service facility.

INSTALLATION
MANUAL REVISION HISTORY

MANUAL REVISION HISTORY

Page Number	Revision Level	Date
i	REV 1.0	JAN 05
ii	REV 1.0	JAN 05
1-1	REV 1.0	JAN 05
1-2	REV 1.0	JAN 05
1-3	REV 1.0	JAN 05
1-4	REV 1.0	JAN 05
1-5	REV 1.0	JAN 05
1-6	REV 1.0	JAN 05
2-1	REV 1.0	JAN 05
2-2	REV 1.0	JAN 05
2-3	REV 1.0	JAN 05
2-4	REV 1.0	JAN 05
2-5	REV 1.0	JAN 05
2-6	REV 1.1	JUN 06
A-1	REV 1.0	JAN 05
A-2	REV 1.0	JAN 05
R-1	REV 1.0	JAN 05